



A BRIGHTER FUTURE
UK LED lighting

Micro X LED Bar 25mm

50,000 Hours

LDT / IES Files

IP54

High CRI option

Dimmable

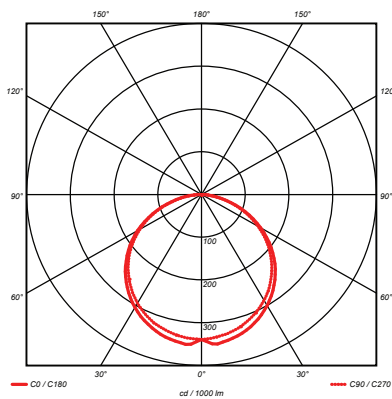

Part No.	E-28-2EC3-24-150-6-SSC2
LED Pitch	25mm
CCT	2400k / 2600k / 2800k / 3000k / 4000k / 5700k
Lumen CRI 85	806 / 975 / 1047 / 1143 / 1241 / 1348
CCT	2600k / 2800k / 3000k / 4000k
Lumen CRI 92	670 / 722 / 861 / 925
Beam Angle	120°
Power Consumption (per met re)	1 2.7 Watts
Volt/DC	24
Chip Used	5630 Seoul Semi conductor
PCB Length (mm)	150/75
Flat end cap combined length (mm)	3+3=6
Straight end cap combined length (mm)	11+11=22
Maximum serial connection (mm)	3500
Tc point °C	50
Lume n/Watt	63-106
Warranty	5 years



Dimensions

Flat end side with red end cap

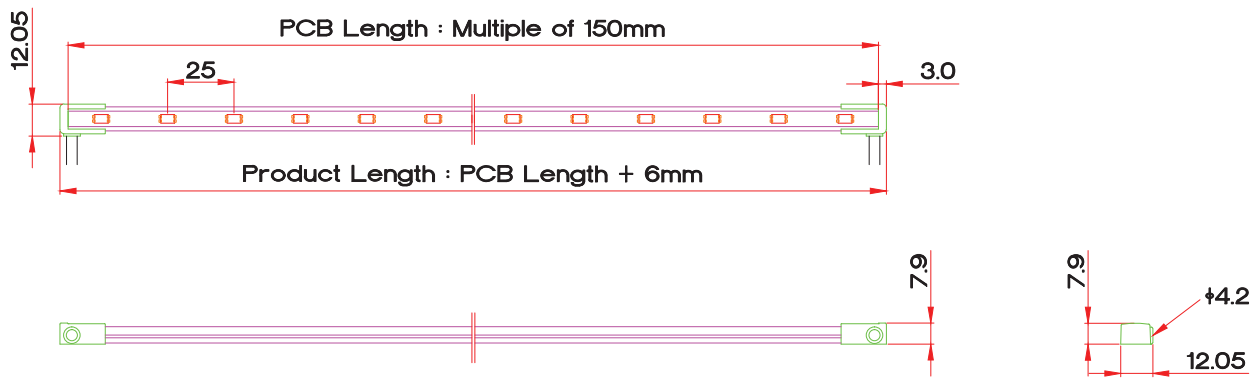

Straight end cap with fixing lug

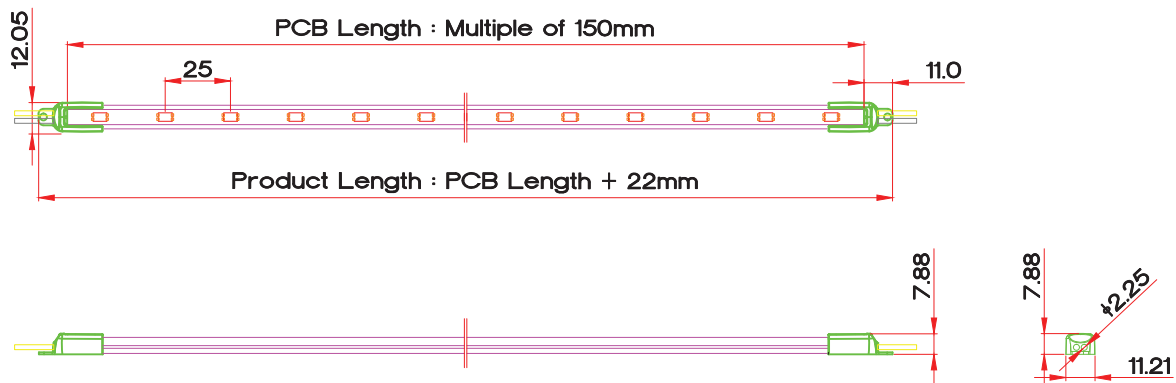

nylon fixing clip

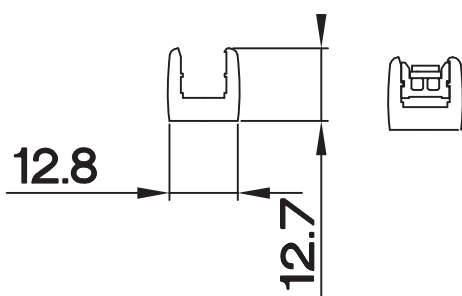

stainle ss steel fixing clip

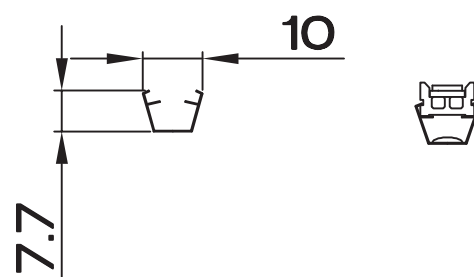

adjustable stainle ss fixing clip

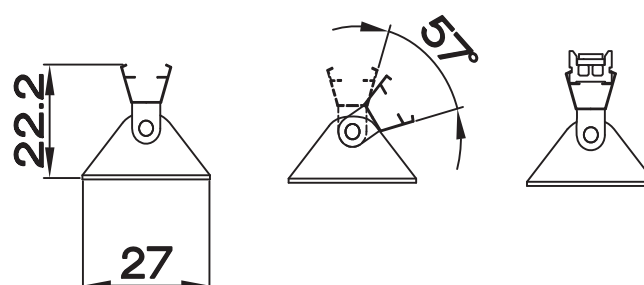

Binning 2 or 3 step MacAdam Ellipse

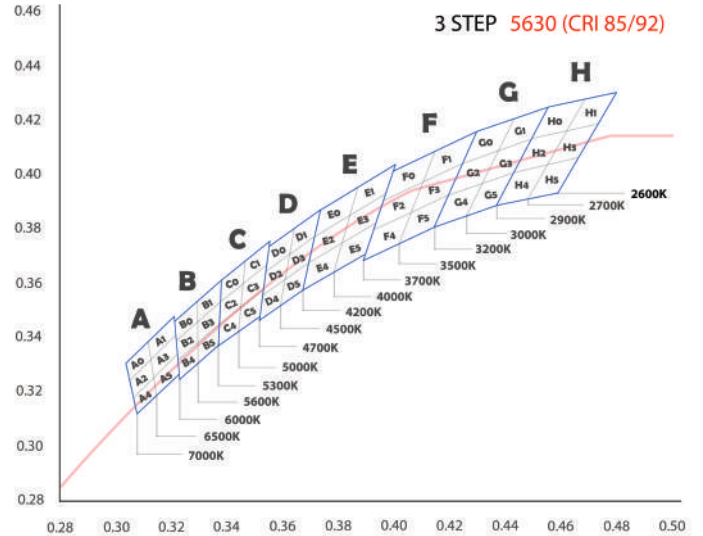
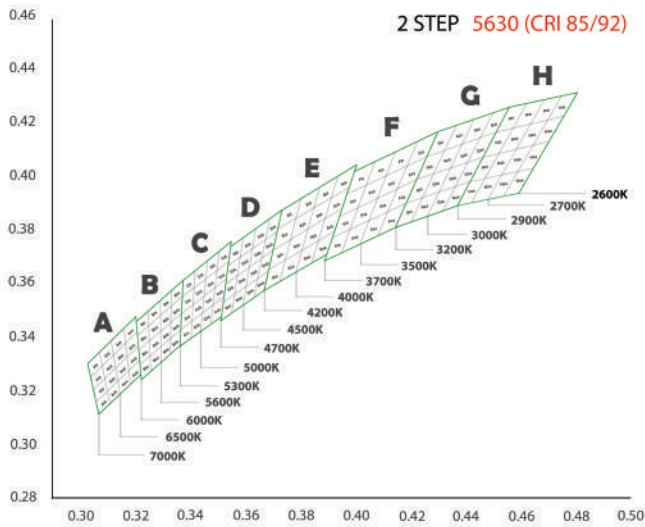

3 Step MacAdam Ellipse by default

Part numbering key

