



A BRIGHTER FUTURE

# UK LED lighting

## Micro LED Bar 8.3mm Pitch

LDT /IES files

IP54

High CRI option

Dimmable

50,000 hours



Part No.	E-28H-3C1-24-75-11-SSC2
LED Pitch	8.3mm
CCT	2200k / 2400k / 2700k / 2800k / 3000k / 4000k / 5700k
Lumen CRI 85	1069 / 1119 / 1353 / 1453 / 1586 / 1721 / 1870
CCT	2600k / 2800k / 3000k / 4000k
Lumen CRI 92	1119 / 1219 / 1353 / 1447
Beam Angle	120°
Power Consumption (per metre)	16.7 Watts
Volt/DC	24
Chip Used	5050 Tri chip Seoul Semiconductor / Samsung
PCB Length (mm)	75
Straight end cap combined length (mm)	11 + 11 = 22
Flat end cap combined length (mm)	3 + 3 = 6
Maximum serial connection (mm)	2400
Tc point °C	55
Lumen/Watt	60-112

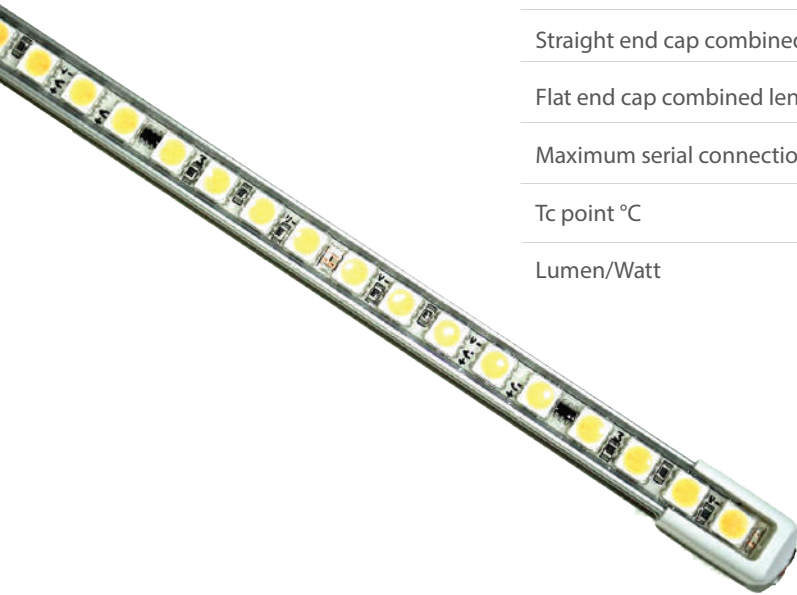
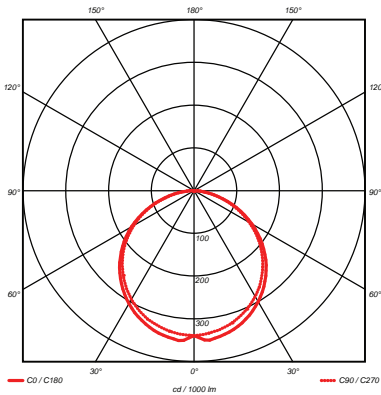

Head Office  
 UK LED Lighting  
 Derby Road  
 Kingsbridge  
 Devon  
 TQ7 1JL  
 Tel: +44 (0)1548 853878  
 Fax: +44 (0)1548 856820  
 Email: enquiries@ukledlighting.com

UK LED Lighting  
 Queens House  
 Paragon Street  
 Hull  
 East Riding of Yorkshire  
 HU1 3NQ

Tel: +44 (0)1482 506333  
 Email: phil.irvin@ukledlighting.com

UK LED Lighting  
 8 Grange Close  
 Buckingham  
 Buckinghamshire  
 MK18 1JJ

Tel: +44 (0)1280 817284  
 Email: barry.mcgowan@ukledlighting.com

# Dimensions

Flat end side wired end cap

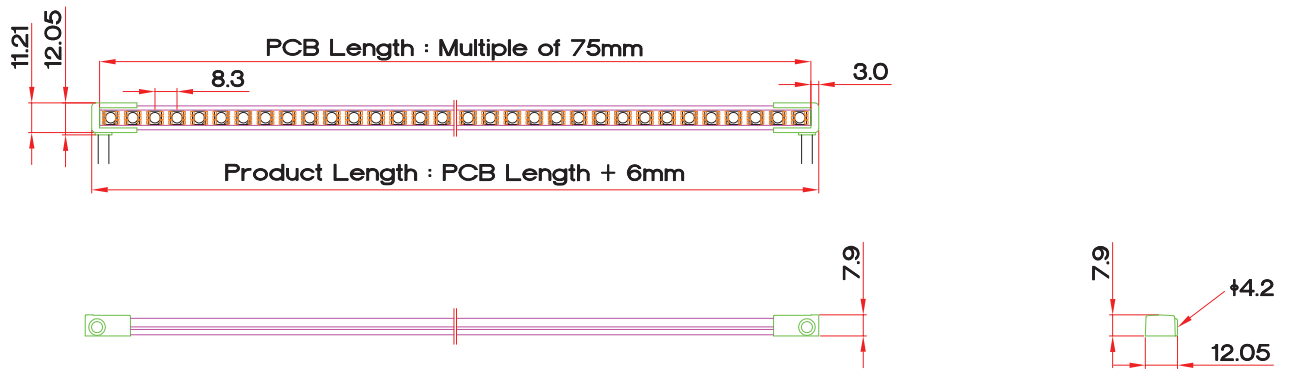

Straight end cap with fixing lug

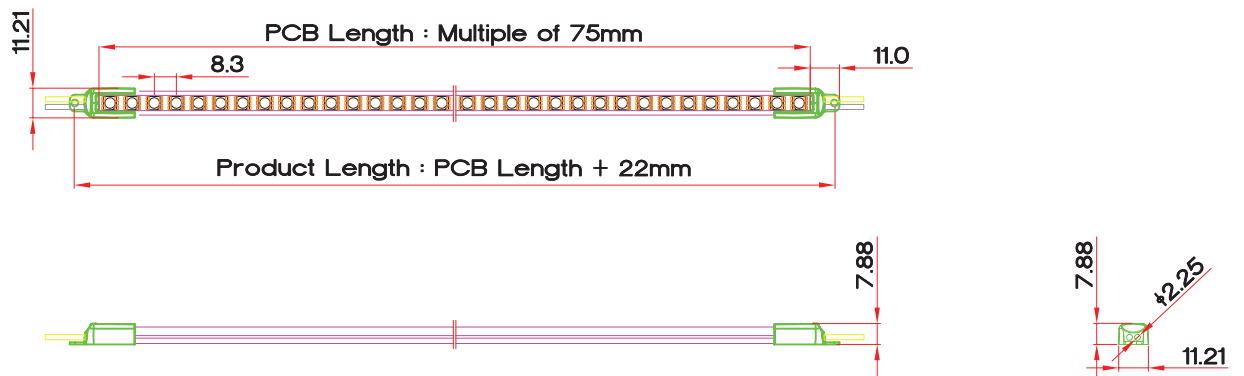

nylon fixing clip

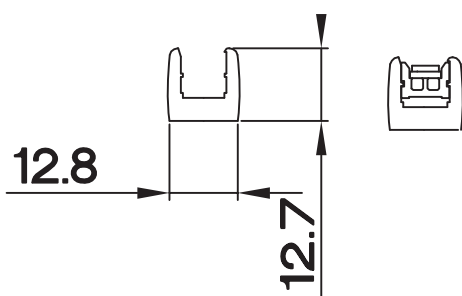

stainless steel fixing clip

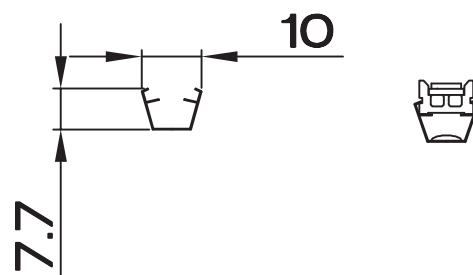

adjustable stainless fixing clip

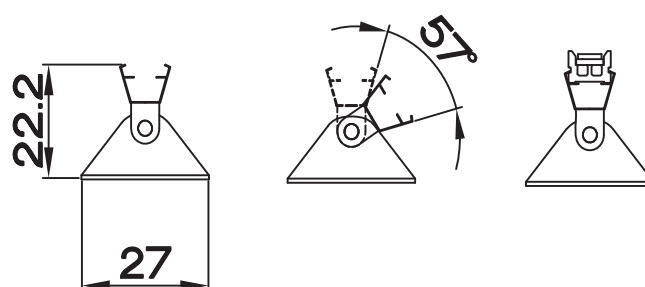

# MacAdam Ellipse - 3 step

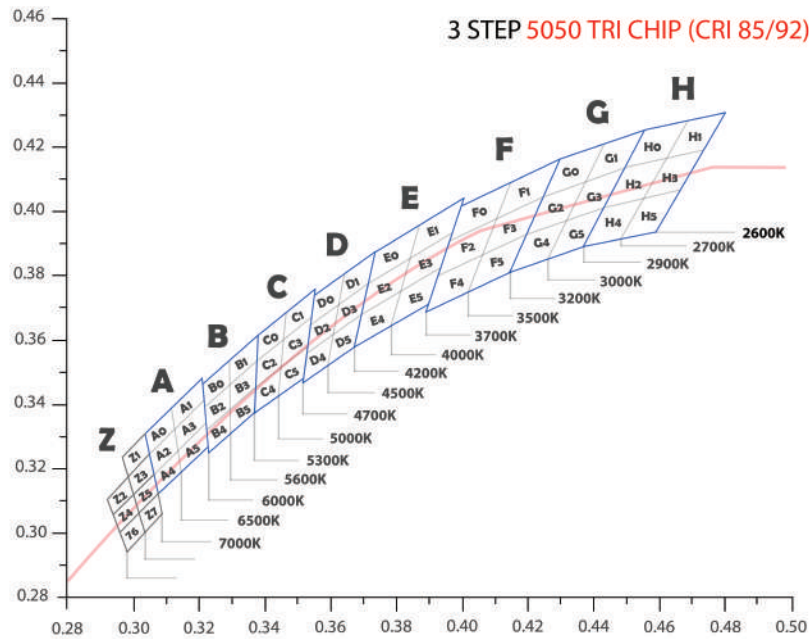

## Part numbering key

